

TOSHIBA

OWNER'S MANUAL

50C450NS / 50M450NS

55C450NS / 55M450NS

65C450NS / 65M450NS

75C450NS / 75M450NS

Owner's Record

You will find the model number and serial number on the back of the TV. Record these numbers in the spaces provided below. Refer to them whenever you call upon your Toshiba TV dealer regarding this product.

Model number:

Serial number:

90891 RSAG2.025.53721SS-1

Find what you want

This TV is equipped with a owner's manual and embedded E-Manual.
Before using the TV, please read the following documentation.

OWNER'S MANUAL

Please read the owner's manual to learn about the following content:

Accessories
Installation
Specifications



E-Manual

To get more information, please check the E-Manual.

Find the E-Manual in **Settings > System > Advanced System > E-Manual.**



E-Manual support functions



QR Code

Scan to open the E-Manual on your mobile device.



Search

Find the help you are looking for.

Important Safety Precautions

Be sure to observe the following instructions and precautions to ensure safe use of this TV.

Stability Hazard

1. WARNING: To prevent injury, this apparatus must be securely attached to a stable surface/wall in accordance with the installation instructions.

Install the TV in a horizontal, stable location.

- If the TV is not installed securely, it may lean or fall over and cause an injury.
- To prevent injury, use the exclusive optional stand or wall-hanging bracket to install this TV on a stable surface or wall securely in accordance with a qualified technician.

- To secure the TV, use a sturdy strap from the hook(s) on the rear of the TV to a wall stud, pillar, or

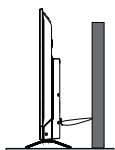

Only for the model with P-clip

other immovable structure. Make sure the strap is tight, secure, and parallel to the floor.

2. Never place the TV in an unstabilized location such as on a shaky table, incline or location subject to vibration.

- Only use cabinets or stands recommended by the TV manufacturer.
- Only use furniture that can safely support the TV.
- Ensure that the TV is not hanging over the edge of the supporting furniture.
- Never place the TV on tall furniture (for example, cupboards or bookcases) without anchoring both the furniture and the TV to a suitable support.
- Never stand the TV on cloth or other material placed between the TV and supporting furniture.

The TV may drop or fall off, which may cause an injury or damage.

- If the existing television set is going to be retained and relocated, the same considerations as above should be applied.

3. Never stand or climb on the TV.

- Educate children about the dangers of climbing on furniture to reach the TV or its controls.

Be especially careful in households with children to prevent them through climbing on top of the TV. It may move, fall over, break, become damaged or cause an injury.

4. Always connect the power plug to an appropriate electrical outlet equipped with 100-240V AC, 50/60Hz.

Never use the TV outside the specified voltage range. It may cause a fire or an electric shock.

About the fuse

In a three pin earthing-type, the fuse fitted in this plug is approved by ASTA or BSI to BS1362. It should only be replaced by a correctly rated and approved type and the fuse cover must be refitted.

About the use

- Make sure to insert the plugs firmly, when plugging the AC power cord into the TV set end and wall outlet end.
- Make sure to hold the plug, when unplugging the AC power cord.
- Never use other cord except for supplied AC power cord, and never use the supplied power cord for any other purpose.

5. Never insert or remove the power plug with wet hands.

This may cause an electric shock.

6. Never block or cover the slots and openings in the cabinet.

- Never place the TV so that it is facing upward or on its side.

Important Safety Precautions

- Never place the TV in a closet, bookcase or other similar area where the ventilation is poor.
- Never drape a newspaper, tablecloth or curtain on the TV.
- When installing the TV against a wall, always keep the TV at least 10cm away from the wall.
- Never place the TV on a soft unstable surface, such as a carpet, or a cushion.

The inside of this TV will overheat if the ventilation holes are covered, blocked or sealed, which may result in a fire.

7. Never place the TV near a heater or in direct sunlight.

The surface of the cabinet or power cord may melt and result in a fire or an electric shock.

8. Never place the TV in an area exposed to high humidity levels, such as in a bathroom or close to a humidifier.

This may cause a fire or an electric shock.

9. Never place the TV next to a stove where it will be exposed to oil, smoke, or steam, or in a location where there is a large quantity of dust.

This may cause a fire or an electric shock.

10. Precautions for moving the TV.

- When moving the TV, be sure to remove the plug from the wall outlet and disconnect the aerial cable and audio/video cables, any steady ties and mounting screw. A fire or an electric shock may result if the power cord is damaged.
- When carrying the TV, at least two people are needed. Be sure to carry it upright.
- Never carry the TV with the screen facing up or down.

11. Precautions for installing on outdoor aerial.

An outside aerial system should not be located in the vicinity of overhead power lines, or other electric light or power circuits.

If the aerial falls down or drops, it may cause an injury or an electric shock.

12. Always route cords and cables connected to your television so they cannot be tripped over, pulled or grabbed.

Use

1. Never place hot objects or open flame sources, such as lighted candles or nightlights, on or close to the TV.

High temperatures can melt plastic and lead to fires.

2. The apparatus shall not be exposed to dripping or splashing and that no objects filled with liquids, such as vases, shall be placed on the apparatus.

When liquids are spilled or small items are dropped inside the TV, this may cause a fire or an electric shock.

If small objects drop inside the TV, turn off the TV and remove the power plug from the outlet immediately and contact a service technician.

3. Never insert objects (metal or paper) or pour water inside the TV through ventilation holes and other openings.

These items may cause a fire or an electric shock. If these objects are inserted inside the TV, turn off the TV and remove the power plug from the outlet immediately and contact a service technician. Be especially careful that children do not insert objects in the TV.

4. When the TV will not be used for a long period of time, such as during vacation or travel, remove the power plug from the wall outlet for safety.

Important Safety Precautions

The TV is not completely disconnected from the power supply line, as minute current is consumed even when the Power switch is turned off.

The Mains plug or an appliance coupler is used as the disconnect device, therefore the disconnect device and socket-outlet shall be easily accessible.

5. Never pull on the power cord when removing the plug from the wall outlet.

Always hold the plug firmly when removing it. If the power cord is yanked, the cord may become damaged and a fire or an electric shock may occur.

6. Never cut, break, modify, twist, bunch up or bent the cord or apply excessive force or tension to it.

Never place heavy objects on the cord or allow it to overheat as this may cause damage, a fire or an electric shock. Contact a service technician if the power cord is damaged.

7. If there is thunder or lightning, never touch the aerial cable or other connected cables.

You may suffer an electric shock.

8. Turn off the TV before unplugging the power cord.

Failure to do so, may cause a malfunction.

9. Listening to music at high volume levels and for extended durations can damage one's hearing.

In order to reduce the risk of damage to hearing, one should lower the volume to a safe, comfortable level, and reduce the amount of time listening at high levels.

10. In dry environment due to static electricity, the product may be restart and return to the main OSD interface, USB player interface or the previous source mode.

You can continue to use the TV when appear this phenomenon.

Service

1. Never repair, modify or disassemble the TV by yourself.

It may cause a fire or an electric shock.

Consult a service technician for inspection and repairs.

2. When a malfunction occurs, or if smoke or an unusual odor comes from the TV, turn off the TV and remove the power plug from the outlet immediately.

Make sure that the smoke or smell has stopped, then contact a service technician. If the TV is still used in this condition, it may cause a fire or an electric shock.

3. If the TV is dropped or the cabinet is broken, turn off the TV and remove the power plug from the outlet immediately.

If the TV has power in this condition, it may cause a fire or an electric shock. If the cabinet is broken, be careful when handling the TV to prevent an injury.

Contact a service technician for inspection and repair.

4. When the TV reaches the end of its useful life, ask a qualified service technician to properly dispose of the TV.

Cleaning

CAUTION: Avoid using chemicals (such as air refreshers, cleaning agents, etc.) on or near the TV pedestal. Studies indicate that plastics may weaken and crack over time from the combination effects of chemical agents and mechanical stress (such as weight of TV). Failure to follow these instructions could result in serious injury and/or permanent damage to TV and TV pedestal.

1. Remove the power plug before cleaning.

Never use solvents such as benzine or thinner to clean the TV.

Important Safety Precautions

- These solvents may distort the cabinet or damage its finish.
- If rubber or vinyl products remain in contact with the TV for a long time, a stain may result.

If the cabinet becomes dirty, clean it with a soft, dry cloth.

When cleaning the surface of the LED display, wipe the panel surface gently with a soft, dry cloth.

2. Periodically disconnect the power plug from the outlet and check it.

If dust has collected on the power plug connectors, clean off the dust with a dry cloth.

This dust may cause a fire due to reduced insulation on the plug.

Important information

1. About LCD screen

- If you have the LCD screen facing to the sun, the LCD screen will be damaged. Be aware of locating the TV close to a window or outdoors.
- Never press the LCD screen strongly or scratch it, and never put anything on it. These actions will damage the LCD screen.

2. About cabinet and LCD screen

Never spray volatile compounds such as insecticide on the cabinet and LCD screen. This may cause a discoloration or damage the cabinet and LCD screen.

3. About afterimage

If a still picture is displayed, an afterimage may remain on the screen, however it will disappear. This is not a sign of malfunction.

4. Some pixels of the screen do not light up

The LCD display panel is manufactured using an extremely high level of precision

technology, however sometimes some pixels of the screen may be missing picture elements or have luminous spots. This is not sign of malfunction.

5. About Interference

The LCD display may cause interference in image, sound, etc. of other electronic equipment that receives electromagnetic waves (e.g. AM radios and video equipment).

6. About using under the low temperature places

If you use the TV in the room of 0°C or less, the picture brightness may vary until the LCD monitor warms up. This is not a sign of malfunction.

7. When disposing of or transferring ownership of the TV

Before disposing of or transferring ownership of the TV, perform "Resetting the TV".

Recording using an USB storage device

- Be sure to select the correct country/region for use.

Use of the recording function may not be possible depending on the selected country/region.

Use with incorrect settings may violate certain laws or other regulations, and may result in criminal punishment.

In such cases, manufacturer shall bear no responsibility whatsoever.

- The recording function has been designed for private use and entertainment in your home environment.

Please note that any commercial use of the recording function could lead to copyright infringement of authors' rights. Manufacturer asks you to respect the intellectual property rights of third parties.

Important Safety Precautions

- Before recording to a device connected to the TV, make a test recording and check the recording performance.
- Manufacturer shall not be liable for compensation or incidental damages of any kind whatsoever resulting from content that was not properly recorded on the recording device or that was modified or lost.
- Manufacturer shall not be liable for damages of any kind whatsoever (breakdown of the recording device, modification or loss of the recorded content, etc.) resulting from malfunction, operating failure or incorrect operation due to combining with another connected device.
- Do not turn off the power supply to the USB storage device or disconnect the connecting cable while the USB storage device is operating. Doing so may result in loss of the recorded data or malfunction of the USB storage device.
- The recording function is not available in all countries/regions.
- Please note that recording on the USB storage device is no longer playable after the TV's main-board is exchanged during service.
- If the time information is incorrect, programed recording may not be performed properly.

Furthermore, if the time information differs according to the currently viewed channel, programed recording may not be performed properly depending on tuning operations.

Exemptions

- Manufacturer is not liable for any damage caused by fires, natural disaster (such as thunder, earthquake, etc.), acts by third parties, accidents, owner's misuse, or uses in other improper conditions.
- Manufacturer is not liable for incidental damaged (such as profit loss or interruption in business, modification or erasure of record data, etc.) caused by use or inability to use of product.
- Manufacturer is not liable for any damage caused by neglect of the instructions described in the owner's manual.
- Manufacturer is not liable for any damage caused by misuse or malfunction through simultaneous use of this product and the connected equipment.

When using a wireless network

CAUTION:

- Bluetooth™ and Wireless LAN devices operate within the same radio frequency range and may interfere with one another. If you use Bluetooth™ and Wireless LAN devices simultaneously, you may occasionally experience a less than optimal network performance or even lose your network connection.
- If you should experience any such problem, immediately turn off either your Bluetooth™ or Wireless LAN device.
- Actual performance can vary, including lower wireless network capacity, data throughput rate, range and coverage.
- Performance depends on many factors, conditions and variables, including distance from the access point, volume of network traffic, building materials and construction, operating system used, mix of wireless products used, interference and other adverse conditions.

Important Safety Precautions

Wireless LAN and your Health

- Wireless LAN products, like other radio devices, emit radio frequency electromagnetic energy. The level of energy emitted by Wireless LAN devices, however, is far less than the electromagnetic energy emitted by wireless devices such as mobile phones.
- Because Wireless LAN products operate within the guidelines found in radio frequency safety standards and recommendations, manufacturer believes Wireless LAN is safe for use by consumers. These standards and recommendation reflect the consensus of the scientific community and result from deliberations of panels and committees of scientists who continually review and interpret the extensive research literature.
- In some situation or environments, the use of Wireless LAN may be restricted by the proprietor of the building or responsible representatives of the organization. Such restrictions may apply in environments where the risk of interference to other devices or services is perceived or identified as harmful.
- If you are uncertain of the policy that applies to the use of wireless devices in a specific organization or environment, you are encouraged to ask for authorization to use the Wireless LAN device prior to turning on the equipment.

 This equipment is a Class II or double insulated electrical appliance.

It has been designed in such a way that it does not require a safety connection to electrical earth.

 AC voltage: This symbol indicates that the rated voltage marked with the symbol is AC voltage.

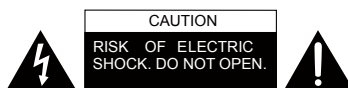

- This lightning flash with arrowhead symbol within an equilateral triangle is intended to alert the user to the presence of non-insulated "dangerous voltage" within the product's enclosure that may be of sufficient magnitude to constitute a risk of electric shock.
- Warning: To reduce the risk of electric shock, do not remove cover (or back) as there are no user serviceable parts inside. Refer servicing to qualified personnel.
- The exclamation point within an equilateral triangle is intended to alert the user to the presence of important operating and maintenance instructions in the literature accompanying the appliance.

Contents

Welcome to Toshiba TV

- Thank you for purchasing this LED TV. This manual will help you use the exciting features of your new TV.
- Instructions in this manual are based on using the remote control.
- Please read all safety and operating instructions in this manual carefully, and keep this manual for future reference.
- LED TV is LCD Panel with LED Backlight.
- Figures and illustrations in this manual are provided for reference only and may differ from actual product appearance.
- Designs and specifications are subject to change without notice.
- Parts of the software function changes with the system upgrade.

Contents

Accessories List	1
Installation	2
TV Front.....	6
TV Rear	7
Making Connections	8
Remote Control	10
Specifications.....	14
Other Information	15

Accessories List

The following accessories are included with TV:

OWNER'S MANUAL × 1 Screw × 4 Base Stand × 2 AAA or AA Battery × 2
Remote Control × 1 Power Cord × 1
Nut × 2 (for installing the wall mount bracket)(only for 50"/55"/65")

NOTE

- The accessories may be different from the list above due to different models, countries / regions. Please refer to the actual accessory bag.

Installation

⚠ CAUTION

- Be sure to disconnect the AC power cord before installing a stand or wall mount brackets.
- The display on your TV is fragile. Make sure the TV screen is not scratched or damaged by hard objects or from pressure.
- After the installation is completed, make sure the TV is steady on a table or firmly attached to a wall mount, before removing all protective film, if any.

► Installing the stand

Follow the illustrations and textual instructions below to complete the installation steps:

1. Carefully place your TV face-down (face-up for 75" models) on a soft, flat surface to prevent damage to the TV or scratching to the screen.
2. Take out the 2 stands from the accessory bag and then insert the stands into the bottom slots of the TV.
3. Secure the stands to the TV with the 4 screws in accessory tightly.

50"/55"

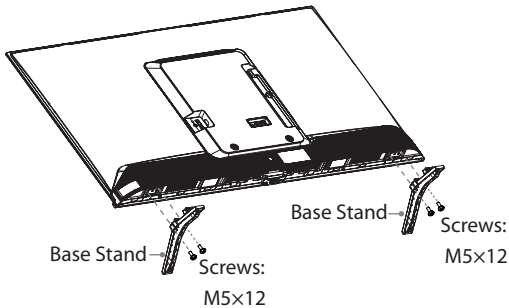

65"

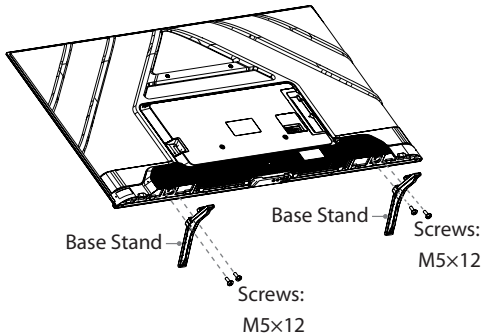

Installation

75"

Note: If your table is long enough to place the TV on top of, then insert the base stands into the screw holes 'A' that are shown in the illustration. If your table is NOT long enough, then insert the base stand into the screw holes 'B' that are shown in the illustration. Note that these two installation methods cannot be mixed.

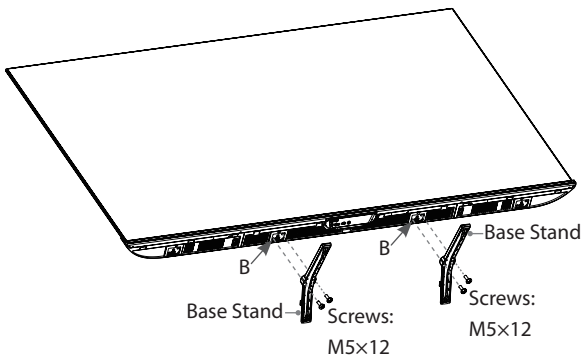
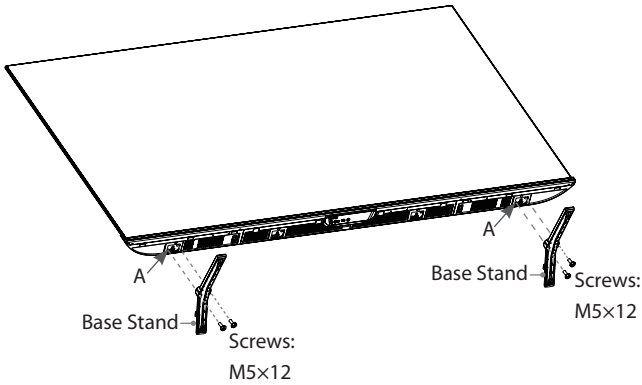

Installation

▶ Installing the wall mount bracket

Before mounting the TV, remove the TV stand if you have already attached it, and make sure the wall mount bracket supports the weight of your TV.

⚠ CAUTION

When mounting the TV on a wall, follow instructions provided with the wall mount bracket. If it is not correctly mounted, the TV may fall and cause property damage or personal injury.

- Take the nuts out of the accessory bag and tighten the nuts with your hands into the holes of the back cover (See Fig. 1) (only for 50"/55"/65").
- Place spacers between the TV and bracket.(See Fig. 2)
- Standard dimensions are shown below.

Wall mount hole pattern (mm)	200 × 400 (50"/55") 300 × 400 (65") 400 × 300 (75")
Wall mount screw size	M6

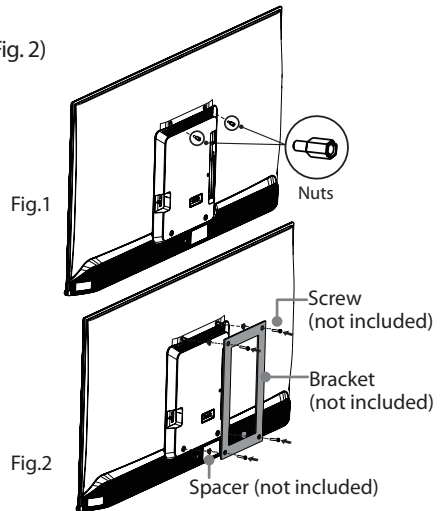
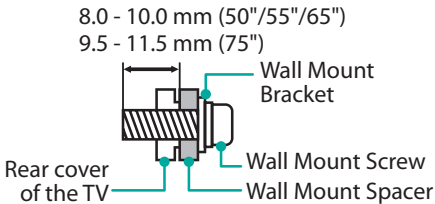

- We do not recommend hanging the TV on a slanted wall, and when wall mounting make sure your television remains parallel to the wall and does not lean forward.

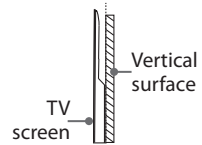

📄 NOTES

- The diameter and length of the screws differ depending on the wall mount bracket model.
- Wall mount bracket is optional. Your TV may not have wall mount bracket. Please refer to the actual accessories.

Installation

► Installing the P-Clip

Please place the TV on a horizontally stable surface, and then use P-Clip to connect the TV and the wall or pillar.

1. Fix **A** part of P-Clip to the screw hole on the back of TV set with a M6×12 screw.
2. Select a suitable hole of P-Clip on **B** part and fix it to the wall or pillar with a ST4×25 screw.

50"/55"

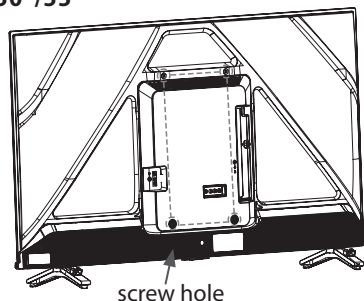

65"

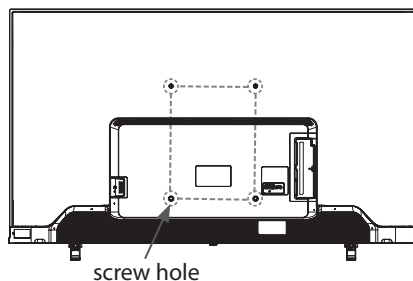

75"

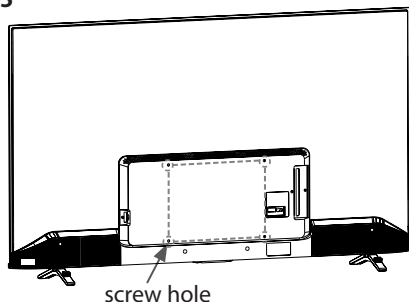

Select a suitable screw hole based on the actual situation

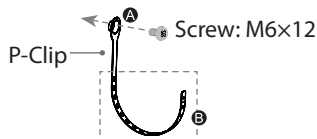



☞ NOTES

- Insecure installation may cause the tilt or falling of the product, and further lead to personal injuries or product damages. If the method above can not fix the product, please consult the manufacturers.
- P-clip and corresponding screws may not included with TV set, please purchase them by yourself if necessary.
- The picture is only for reference.

TV Front

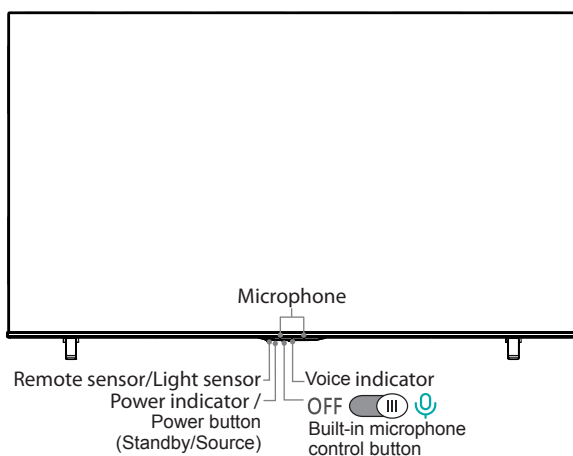
TV Front



<i>Item</i>	<i>Description</i>
Remote sensor	Receives remote signals from the remote control. Do not put anything near the sensor, as its function may be affected.
Power indicator	The light is white in standby mode.
 Standby / Source	<ul style="list-style-type: none"> ▶ When the TV is in standby mode, press the single button to turn on your TV. ▶ When the TV is on: <ul style="list-style-type: none"> • Press the single button: Display the menu. / Move focus. • Press and hold the single button: Confirm the selection. • If there's no operation for 3 seconds, the menu will hide automatically.
Built-in microphone control button	Switch the button to  to turn on built-in microphone. Say "Hey Google" to start a conversation. Before using this function, connect the TV to the Internet and sign in your Google account.

NOTES

- Powering on the TV requires several seconds to load programmes.
- Do not rapidly turn the TV off as it may cause the TV work abnormally.
- Before using Google Assistant, connect your TV to the network. The Google Assistant and some of its features are available on limited country/region/language.

TV Rear

TV Rear

50"/55"

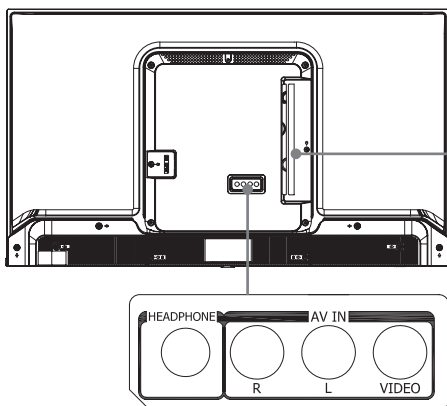

65"/75"

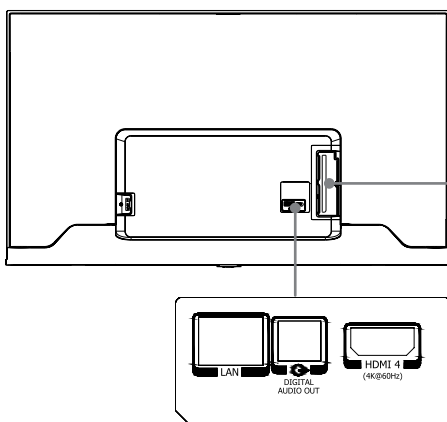







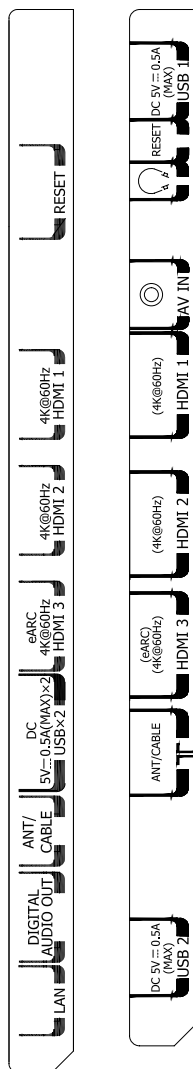





NOTES

- Check the jacks for position and type before making any connections. Loose connections can result in image or color problems. Make sure that all connections are tight and secure.
- Not all A/V devices have the ability to connect to a TV, please refer to the user's manual of your A/V device for compatibility and connections procedure.
- Before connecting external equipment, remove the mains plug from the wall socket. Otherwise, it may cause electric shock.

50"/55" 65"/75"



Making Connections

ANT/CABLE		Connect an outdoor VHF/UHF antenna or cable.
HDMI		Connect an HDMI cable from an external A/V equipment.
HDMI (eARC)		Connect an HDMI cable from an external digital audio system.
AV IN		Connect a composite video cable and left-right audio cables from an external AV device. The VIDEO can be used to connect a range of equipment, including video recorders, camcorders, decoders, satellite receivers, DVD players, or games consoles.
	VIDEO 	
	L 	
	R 	
USB		Connect a USB device for browsing photos, music and movies.
DIGITAL AUDIO OUT		Connect an optical cable from an external digital audio system.
LAN		Connect an Ethernet cable to access a network or the Internet.
HEADPHONE 		Connect headphones to listen to the sound coming from the TV. Note: Excessive sound pressure from earphones can cause hearing loss.
RESET		Power off / restart (quick press) Reset your TV back to the factory setting (long press for 5 seconds)

NOTES

- The location and names of the terminals on the TV may vary according to TV model, and not all terminals available on all models.

Making Connections

► LAN (Wired setup)

Connect your TV to your network by connecting the LAN port on the back of your TV to an external modem or router using a LAN (Ethernet/Cat 5) cable. See the illustration below.

- It is recommended to use a modem or router that supports Dynamic Host Configuration Protocol (DHCP). Modems and routers that support DHCP automatically provide the IP address, subnet mask, gateway, and DNS, so you don't have to enter them manually. Most home networks already have DHCP.

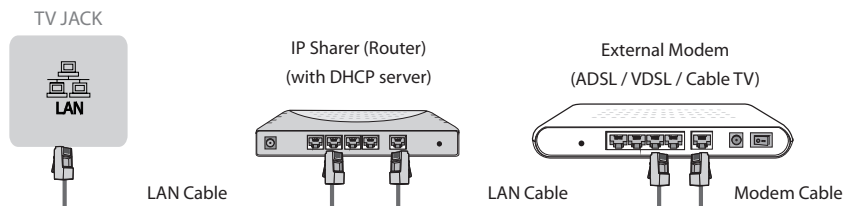

Wireless setup

To connect your TV to your network wirelessly, you need a wireless router or modem. See the illustration below.

- The built-in Wireless LAN Adapter supports the IEEE 802.11a/b/g/n/ac communication protocols. It is recommended to use IEEE 802.11ac router. Low transfer rates for b/g may have the influence on the quality of streamed videos and other media.



☒ NOTES

- You must use the built-in Wireless LAN Adapter to use a wireless network because the set doesn't support external USB network adapters.
- If the wireless router supports DHCP, your TV can connect more easily to the wireless network.
- If you apply a security system other than the systems listed below, it will not work with the TV. Security system: WPA, WEP, WPA2.
- In order to guarantee smooth network, the distance between router and TV should be less than 10 metres.

Remote Control

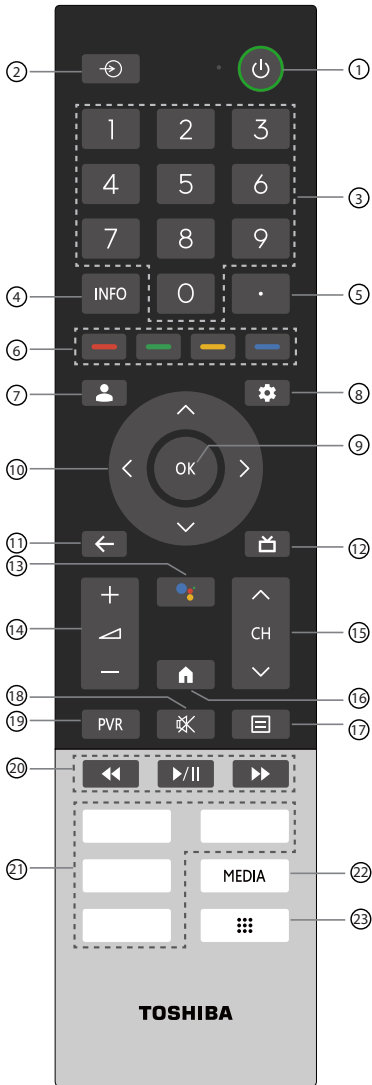

- ① Turn the TV on or into standby mode
- ② Select input source
- ③ Select a channel or input numbers
- ④ Display the present program information
- ⑤ Input decimal point
- ⑥ Special function buttons
- ⑦ Accounts & Sign In or switch profile
- ⑧ Access the settings (direct or through the dashboard in GTV) from any place in the system
- ⑨ OK / Confirmation button
- ⑩ D-pad: Allow you to navigate the OSD menus and adjust the system settings to your preference
- ⑪ Return to previous menu
- ⑫ Enter to Live tab in launcher/Display the Electronic Program Guide (if support)/Return to Live TV*
- ⑬ Google Assistant of TV
- ⑭ Adjust the volume
- ⑮ Switch Channel
- ⑯ Display the Home screen
- ⑰ Setting Menu
- ⑱ Mute or restore the TV sound
- ⑲ Quick access button to PVR
- ⑳ Media content control function buttons
- ㉑ Quick access buttons to apps
- ㉒ Enter the media mode
- ㉓ Fast access to all apps

NOTES

- * Pressing the button in different scenarios will have different responses.
- The image is for reference only and may differ from actual product appearance.
- The included remote control will vary depending on models/countries/regions, check information according to the actual remote control in the accessory bag.

Remote Control

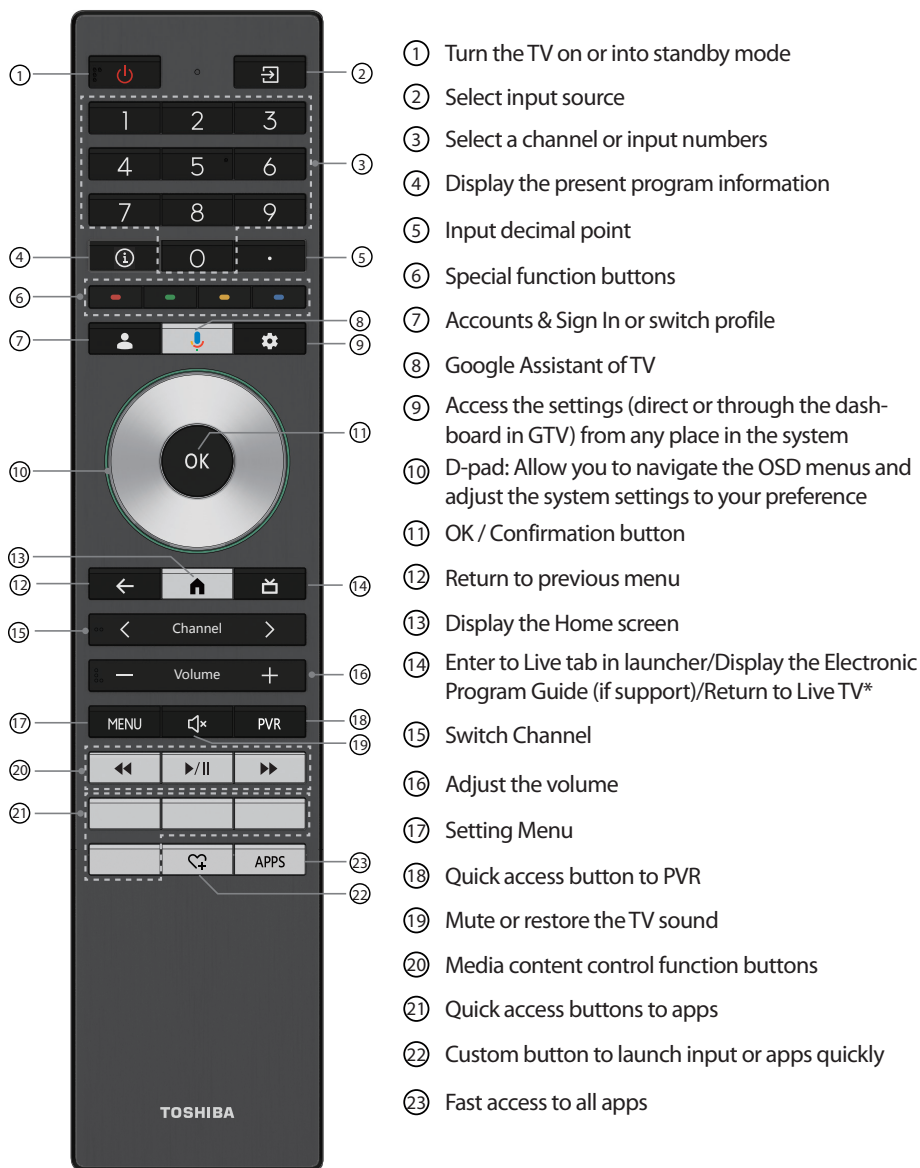

NOTES

- * Pressing the button in different scenarios will have different responses.
- The image is for reference only and may differ from actual product appearance.
- The included remote control will vary depending on models/countries/regions, check information according to the actual remote control in the accessory bag.

Remote Control

► Installing Batteries in the Remote Control

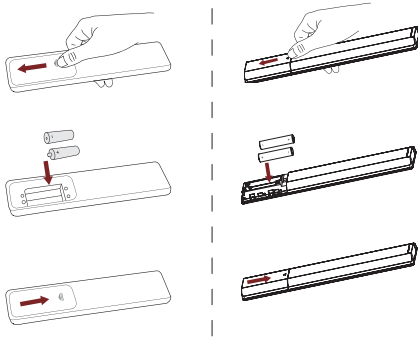

1. Slide the back cover to open the battery compartment of the remote control.
2. Insert two AAA or AA size batteries. Make sure to match the (+) and (-) ends of the batteries with the (+) and (-) ends indicated in the battery compartment.
3. Close the battery compartment with the cover.

📖 NOTES

- Product image is only for reference, actual product may vary in appearance.

Handling the Batteries

- Incorrect use of batteries may cause corrosion or battery leakage, which could cause fire, personal injury or damage to property.
- Only use the battery type indicated in this manual.
- Do not mix old and new batteries or different types of batteries.
- Do not dispose of used batteries as domestic waste. Dispose of them in accordance with local regulations.
- Battery chemicals can cause a rash. If the batteries leak, clean the battery compartment with a cloth. If chemicals touch your skin, wash immediately.
- If you do not intend to use the remote control for a long time, remove the batteries.
- Remove depleted batteries immediately to prevent battery acid from leaking into the battery compartment.
- Do not expose batteries to excessive heat such as sunshine, fire or the like.

Remote Control

► Pairing the Remote Control (only for Bluetooth remote control)

1. Pair the remote to the TV after you power it on for the first time. Keep the remote control within 3 metres from the TV. Press and hold the [←] button and [🏠] button at the same time at least 3 seconds to start pairing.
2. If the remote pairs successfully, a confirmation will display on the screen. If it does not pair successfully, an unsuccessful message will display. Repeat step 1.

📄 NOTES

- If an unknown error occurred with the remote, then it could have been caused by interference. Try to remove what's causing the interference and pair it again.
- If an unknown error occurred in the remote control while the battery power is normal, you can take out the batteries, press any key for 1~2 seconds, and insert them back. Then the remote control will work normally.
- The remote cannot be paired to the TV while the TV is in standby mode.

► Remote Control Operation Range

1. The remote control can work at a distance of up to 8 metres in front of the TV set.
2. The remote control angle: taking the remote sensor as an apex, 6 metres away, its controlled horizontal angle is within $\pm 30^\circ$, while the vertical angle is within $\pm 15^\circ$.
3. The operating distance may vary depending on the brightness of the room.

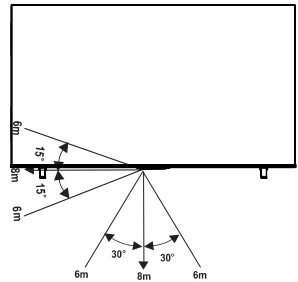

Disposal of this unit

Product should not be damaged, dismantled or thrown in municipal waste. It should be packed and handed over to authorised re-cycler.

Specifications

☑ Features, appearance and specifications are subject to change without notice.

Item		50"	55"
Dimension (W × H × D)	Without Stand	1119 × 653 × 79 mm	1233 × 718 × 80 mm
	With Stand	1119 × 692 × 274 mm	1233 × 757 × 273 mm
Weight	Without Stand	8.7 kg	10.9 kg
	With Stand	8.8 kg	11.0 kg
Active Screen Size (Diagonal)		125.7 cm	138.7 cm
Screen resolution		3840 × 2160	3840 × 2160
Audio power		8 W + 8 W	8 W + 8 W
Item		65"	75"
Dimension (W × H × D)	Without Stand	1453 × 842 × 76 mm	1676 × 965 × 87 mm
	With Stand	1453 × 893 × 318 mm	1676 × 1021 × 337 mm
Weight	Without Stand	14.6 kg	22.9 kg
	With Stand	14.9 kg	23.2 kg
Active Screen Size (Diagonal)		163.8 cm	189.3 cm
Screen resolution		3840 × 2160	3840 × 2160
Audio power		10 W + 10 W	15 W + 15 W
Power consumption		Please refer to the rating label.	
Power supply		Please refer to the rating label.	
Receiving systems	Analog	NTSC, PAL M/N	
	Digital	ATSC, ISDB-T with EWBS (only for Philippines), ISDB-T, DVB-T2(6M)	
Environmental conditions		Temperature: 5°C - 45°C Humidity: 20% - 80% RH Atmospheric pressure: 86 kPa - 106 kPa	
HDMI Input		RGB/60Hz (640×480, 800×600, 1024×768) YUV/50Hz (576i, 576p, 720p, 1080i, 1080p) YUV/60Hz (480i, 480p, 720p, 1080i, 1080p) 24Hz 25Hz 30Hz 50Hz 60Hz (3840×2160)	

NOTE: "Receiving systems" may differ depending on your model/country/region.

Other Information



The terms HDMI, HDMI High-Definition Multimedia Interface, HDMI Trade dress and the HDMI Logos are trademarks or registered trademarks of HDMI Licensing Administrator, Inc.



Dolby, Dolby Vision, Dolby Atmos, and the double-D symbol are registered trademarks of Dolby Laboratories Licensing Corporation. Dolby Vision IQ is a trademark of Dolby Laboratories Licensing Corporation. Manufactured under license from Dolby Laboratories. Confidential unpublished works. Copyright © 2012-2022 Dolby Laboratories. All rights reserved.



For DTS patents, see <http://patents.dts.com>. Manufactured under license from DTS Licensing Limited. DTS, DTS:X, and the DTS:X logo are registered trademarks or trademarks of DTS, Inc. in the United States and other countries. © 2021 DTS, Inc. ALL RIGHTS RESERVED.

This equipment is not entitled to protection from harmful interference and cannot cause interference in duly authorized systems.

Disposal of Used Electrical & Electronic Equipment

Packaging and electrical goods should be recycled appropriately, and not treated as household waste. Please dispose of this equipment at your applicable collection point for the recycling of electrical & electronic equipment waste. By ensuring the correct disposal of this product, you will help prevent potentially hazardous to the environment and to human health, which could otherwise be caused by unsuitable waste handling of this product. The recycling of materials will help conserve natural resources. Please do not therefore dispose of your old electrical and electronic equipment with your household waste. For more detailed information about recycling of this product, please contact your local city office, your household waste disposal service or the shop where you purchased the product.

